

Solstart Plus

Analog Soft Starter
31-170A, 208-600V

Instruction Manual

Ver. 23/03/09

Softstart UK's Solstart Plus Instruction Manual

1. INDEX

1.	Index	2
2.	Safety & Warnings	3
2.1	Safety	3
2.2	Attention	3
2.3	Warnings	3
3.	Technical Data	4
3.1	Introduction	4
3.2	Rating and frames sizes.....	4
3.3	Starter Selection	4
3.4	Mains and control description	5
3.4.1	Mains Voltage (line to line)(Terminals/bars L1, L2, L3)	5
3.4.2	Control Voltage (Terminals 1, 2)	5
3.4.3	Discrete input voltage (Terminals 3, 4)	5
3.4.4	End Of Acceleration (terminals 5, 6)- Solstart Plus 58A and up.	5
3.4.5	Fault Contact (terminals 7, 8).....	5
3.5	Built-in Bypass	5
3.6	Soft starter protections	6
3.6.1	Electronic Overload	6
3.6.2	Phase Loss.....	6
3.6.3	Under voltage	6
3.6.4	Heatsink over temperature protection.....	6
3.6.5	Fault Logic and Reset Circuits	6
3.7	Starter selection tables for various voltage ratings.	7
3.7.1	Ordering Information.....	8
4.	Recommended Wiring Schemes	9
4.1	Typical wiring diagram	9
4.2	Wiring Notes	9
4.2.1	Short Circuit Protection.....	10
4.2.2	Transient Protection	10
5.	Dimensions	11
6.	Installation	12
6.1	Prior to Installation	12
6.2	Mounting	12
6.3	Temperature range & heat dissipation	13
6.3.1	Calculating the enclosure size, for non-ventilated metallic enclosure.....	13
6.3.2	Additional Ventilation	13
7.	Control Keypad	14
7.1	Potentiometers settings.....	14
7.2	Indication LEDs and RESET button	16
8.	STARTING PROCEDURE	17
8.1	Standard starting procedure.....	18
8.2	Examples of starting curves	19
9.	TROUBLE SHOOTING	20
9.1	Warranty Claim and Fault Inquiry	21
10.	TECHNICAL SPECIFICATIONS	22

2. SAFETY & WARNINGS

2.1 Safety

	1	Read this manual carefully before operating the equipment and follow its instructions.
	2	Installation, operation and maintenance should be in strict accordance with this manual, national codes and good practice.
	3	Installation or operation not performed in strict accordance with these instructions will void manufacturer's warranty.
	4	Disconnect all power inputs before servicing the soft-starter and/or the motor.
	5	After installation, check and verify that no parts (bolts, washers, etc) have fallen into the starter.
	6	During shipping, the soft-starter might have been roughly handled, therefore, it is recommended to initialize the soft-starter by connecting supply voltage prior to operating the soft-starter with a motor

2.2 Attention

	1	This product was designed for compliance with IEC 947-4-2 for class A equipment.
	2	Use of the product in domestic environments may cause radio interference, in which case, the user may be required to employ additional mitigation methods.
	3	Utilization category is AC-53a or AC53b, Form 1. For further information, see Technical Specification

2.3 Warnings

	1	Internal components and P.C.Bs are at mains potential when the Solstart Plus is connected to mains. This voltage is extremely dangerous and will cause death or severe injury if contacted.
	2	When Solstart Plus is connected to mains, even if control voltage is disconnected and motor is stopped, full voltage may appear on starter's output and motor's terminals.
	3	The starter must be grounded to ensure correct operation, safety and to prevent damage.
	4	Check that Power Factor capacitors are not connected to the output side of the soft starter.
	5	Do not interchange line and load connections

The company reserves the right to make any improvements or modifications to its products without prior notice.

3. TECHNICAL DATA

3.1 Introduction

The Solstart Plus electronic soft starter incorporates four thyristors (Two phase control) to start a three-phase squirrel cage induction motor.

By supplying a slowly increasing voltage, it provides soft start and smooth stepless acceleration, while drawing the minimum current necessary to start the motor.

A Soft Stop feature can be enabled when the Ramp-Down potentiometer is adjusted. When used, upon stop signal (disconnect discrete input voltage from terminals 3 and 4), motor's voltage is slowly reduced to zero.

The Solstart Plus incorporates a built in motor protection of Overload protection, phase loss protection and under voltage protection.

The Solstart Plus incorporate an internal protection to protect its heatsinks from over heating.

3.2 Rating and frames sizes

Solstart Plus model	FLC [A]	Dimensions WxHxD [mm]	EOA Relay	Fault Relay	Aluminium case	Din Rail mounted
Solstart Plus 31	31	65x190x114	-	✓	✓	O
Solstart Plus 44	44	65x190x114	-	✓	✓	O
Solstart Plus 58	58	120x265x121	✓	✓	✓	-
Solstart Plus 72	72	120x265x121	✓	✓	✓	-
Solstart Plus 85	85	120x265x121	✓	✓	✓	-
Solstart Plus 105	105	120x265x121	✓	✓	✓	-
Solstart Plus 145	145	129x275x182	✓	✓	✓	-
Solstart Plus 170	170	129x275x182	✓	✓	✓	-

Notes:

- (O) – Optional
- EOA – End Of Acceleration Relay available in Solstart Plus models 58A and up.
- Refer to section 5 on page 11 for detailed dimensions.

3.3 Starter Selection

Select the starter according to motor's Full Load Ampere (FLA) - as indicated on its nameplate (even if the motor will not be fully loaded).

The Solstart Plus is designed to operate under the following maximum conditions:

Ambient Temperature [°C]	Starting Current [A]	Acceleration Time [sec]
40	300% \times In	15
	350% \times In	10
	400% \times In	5

Max. starts per Hour: four (4) starts per hour at maximum ratings and up to 10 starts per hour at light load applications (consult factory).

Note:

For very frequent starts (inching applications) the inching current should be considered as the Full Load Current (FLC) (consult factory).

3.4 Mains and control description

3.4.1 Mains Voltage (line to line)(Terminals/bars L1, L2, L3)

Four mains voltage levels are available: 208V, 400V, 480V, 600V.

Note:

208V applies for 208V-10% up to **220V**+15%

400V applies for 400V-10% up to 400V+15%

480V applies for 480V-10% up to 480V+15%

600V applies for 600V-10% up to 660V+15%

3.4.2 Control Voltage (Terminals 1, 2)

The Solstart Plus incorporates a universal power supply unit for DC and AC control voltage.

110-230V, 50/60Hz or 110-230VDC (+10%/ -15%) is required to power the electronic circuitry and the bypass.

This voltage can be from a grounded or ungrounded mains system.

3.4.3 Discrete input voltage (Terminals 3, 4)

Apply discrete input voltage to terminals 3 and 4 to soft start the motor.

To stop the motor disconnect the control voltage from terminals 3 and 4. If Deceleration time is set to a value other than 0 seconds the motor will soft stop.

Discrete input voltage should be in the same range as control voltage: 110-230V, 50/60Hz or 110-230VDC (+10%/ -15%).

This voltage can be from a grounded or ungrounded mains system.

3.4.4 End Of Acceleration (terminals 5, 6)- Solstart Plus 58A and up.

This contact exists in Solstart Plus 58A and up.

Voltage free, N.O., 8A / 250VAC, 1800VA max.

The contact closes after the time adjusted on the "Ramp-Up" potentiometer. The contact returns to its original position on stop signal, on fault condition, upon voltage outage and at the beginning of Soft Stop.

This contact can be used for:

- Activating a valve after a compressor has reached full speed.
- Activating a valve after a pump has reached full speed.
- Loading a conveyor after the motor has reached full speed.

3.4.5 Fault Contact (terminals 7, 8)

Voltage free, N.O , 8A, 250VAC, 1800VA max. Solstart Plus 58A and up.

Voltage free, N.O , 5A, 250VAC, 1250VA max. Solstart Plus up to 44A.

The contact changes its position upon fault and returns to its original position after fault has been removed and starter was reset. When disconnection of control supply the contacts will be opened.

3.5 Built-in Bypass

The Solstart Plus incorporates two internal bypass relays allowing current flow through the thyristors only during starting process. At the end of the starting process, the built-in relays bypass the thyristors and carry the current to the motor.

Upon stop signal, or in case of fault, both bypass relays will open and stop the motor.

When Ramp-Down potentiometer is set to allow soft-Stop process, upon stop command, the bypass relays will open immediately and the current will flow through the thyristors. The voltage will then be reduced slowly and smoothly to zero.

3.6 Soft starter protections

3.6.1 **Electronic Overload**

The built-in inverse time electronic overload becomes operational after 15 seconds. (This is the maximum starting time of the Solstart Plus).

Trip current is factory set to 115% of Motor Full Load Current (from the setting on Motor FLC potentiometer), E.g. In order to increase the O/L trip point increase FLC setting above the calculated level.

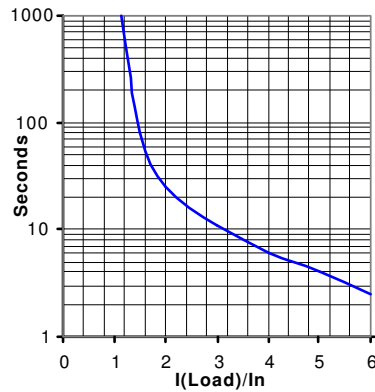

Electronic overload curve

When this protection activates Overload LED on the front panel will lit.

3.6.2 **Phase Loss**

The protection becomes operational when the starter is energized.

it protects the motor from single phasing. It will trip the starter when one or two phases are missing for more than 1 sec.

When this protection activates Fault LED on the front panel will lit.

3.6.3 **Under voltage**

The protection becomes operational when the starter is energized.

it protects the motor from under voltage. It will trip the starter when under voltage condition occurs for more than 1 sec.

When this protection activates Fault LED on the front panel will lit.

3.6.4 **Heatsink over temperature protection.**

The protection becomes operational when the starter is energized.

it protects the soft starter from over heating.

A thermal sensor mounted on the heatsink trips the starter when its heatsink temperature rises above 85°C.

When this protection activates fault LED on the front panel will **flash**.

3.6.5 **Fault Logic and Reset Circuits**

Upon operation of any protection, the starter locks in a fault mode, disabling thyristors firing and opening the Bypass. The proper fault indication LED lit/flash and the Fault contact closes.

To reset the starter, after the fault has been removed, press Reset button on starter's front panel or disconnect control voltage.

WARNING!

When Fault occurs make sure that Discrete Input Voltage (terminals 3, 4) is disconnected otherwise upon Reset the motor will start immediately!!

WARNINGS!

The heatsink over temperature protection is designed to operate under normal conditions and will operate in case abnormal conditions occur:

- Incorrect starter selection
- Too frequent starting at maximum conditions
- Repeated starting under fault conditions
- Extended low overload
- Insufficient ventilation
- Other abnormal conditions

Note-

In case of frequent starting the internal thyristors may overheat before the heatsink reaches its over-temperature protection of 85°C, thus causing component malfunction.

3.7 Starter selection tables for various voltage ratings.

	1	The starter selection table below concern standard, 1500r.p.m. 50Hz, three-phase motors.
	2	These values are given for guidance and may vary according to motor manufacturer and depending on the number of poles.
	3	It is the user's responsibility to make sure that motor's FLA will never exceed Starter's FLC.

Starter type	Starter FLC [A]	Motor kW @230V [kW]	Motor kW @400V [kW]	Motor kW @480V [kW]	Motor kW @600V [kW]
Solstart Plus 31	31	8	15	18.5	25
Solstart Plus 44	44	12.5	22	25	30
Solstart Plus 58	58	15	25	37	45
Solstart Plus 72	72	20	37	45	59
Solstart Plus 85	85	25	45	55	59
Solstart Plus 105	105	30	55	59	80
Solstart Plus 145	145	40	75	90	110
Solstart Plus 170	170	51	90	110	140

3.7.1 **Ordering Information****Solstart Plus****31-
Full load
Current****400-
Mains
Voltage****2-
Control
Voltage****0-
Options****S
Front
Panel****Full load Current**

Specify	Description
Starter's FLC [A]	31, 44, 58, 72, 85, 105, 145, 170

Mains Voltage

Specify	Description
208	208V 50/60Hz (208V-15% to 220V +10%)
400	400V 50/60Hz (400V-15% to 400V+10%)
480	480V 50/60Hz (480V-15% to 480V+10%)
600	600V 50/60Hz (600V-15% to 600V+10%)

Control Voltage

Specify	Description
2	110 – 230 VAC50/60Hz/DC -15% - +10%
Note:	<ul style="list-style-type: none"> Solstart Plus incorporates a universal power supply unit for DC and AC control voltage.

Options

Specify	Description
0	No options
8	Harsh environment treatment
DRM	DIN rail mounting accessory. ⁽¹⁾
Notes:	<ul style="list-style-type: none"> For more than one option indicate, for example: 8+DRM (Harsh environment and DIN rail mounting accessory) Options must be factory installed. ⁽¹⁾ DIN rail mounting accessory is available for models 31-44A.

Front Panel

Specify	Description
S	Standard lexan

Example:

Solstart Plus rated 145A, mains voltage- 208V, control voltage- 110V DC, Harsh environment treatment and standard front panel:

Solstart Plus 145 - 208 - 2 - 8 – S

4. RECOMMENDED WIRING SCHEMES

4.1 Typical wiring diagram

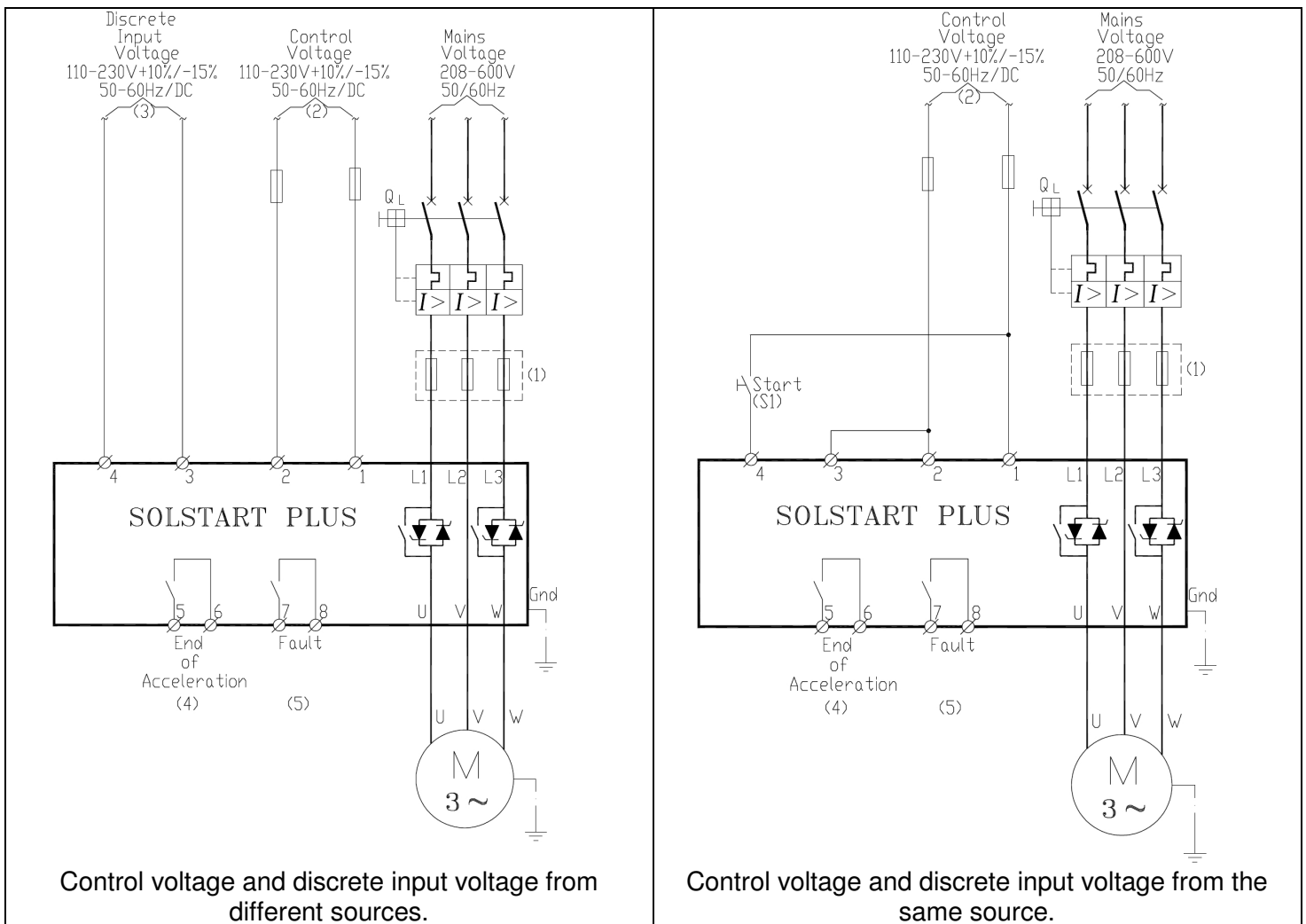

Notes:

- (1) - Use fuses for type 2 coordination. Refer to section 4.2.1 on page 10
- (2) - Solstart Plus incorporates a universal power supply unit for DC and AC control voltage: 110-230V 50/60Hz or 110-230VDC.
- (3) – Discrete input voltage can be either 110-230V 50/60Hz or 110-230VDC. This voltage can be from a different voltage system than the control voltage or of the same system.
- (4) – End Of Acceleration contact (EOA) exist in models Solstart Plus 58 and up.
- (5) – Fault contact closes in fault conditions.
- (6) - When emergency stop switch is required it is recommended to trip a series contactor or the feeding circuit breaker. (Not shown)

4.2 Wiring Notes

WARNINGS!

When mains voltage is connected to the Solstart Plus, even if control voltage is disconnected, full voltage may appear on the starter load terminals. Therefore, for isolation purposes, it is necessary to connect an isolating device before the starter.

Power factor correction capacitors must not be installed on starters load side. When required, install capacitors on starter's line side.

Never connect the Solstart Plus "Inside Delta"!

4.2.1 **Short Circuit Protection**

For “class 2 coordination”, protect the starter against a short circuit by thyristor protection fuses for I²t and fuses as in dictated in the following table:

Solstart Plus Model	Max. thyristor I ² t [A ² Sec]	BUSSMAN	
		Rate [A]	P/N
Solstart Plus 31	4,000	90	FWP 90B
Solstart Plus 44	9,100	125	FWP 125B
Solstart Plus 58	18,600	150	FWP 150B
Solstart Plus 72	80,000	175	FWP 175B
Solstart Plus 85	125,000	200	FWP 200A
Solstart Plus 105	125,000	200	FWP 200A.
Solstart Plus 145	281,000	300	FWP 300A
Solstart Plus 170	320,000	300	FWP 300A

Notes:

1. The above table is for maximum starting current of 400% of FLC, maximum starting time of 5 sec and rated voltage of 400 V.
2. Rating may change with different external conditions such as ambient temperature, forced cooling etc. Refer to fuse manufacturer catalogs to confirm correct values.

4.2.2 **Transient Protection**

Line transient voltages can cause a malfunction of the starter and damage to the thyristors. All Solstart Plus starters incorporate Metal Oxide Varistors (MOV) to protect from normal line voltage spikes.

When higher transients are expected, additional external protection should be used (consult factory).

5. DIMENSIONS

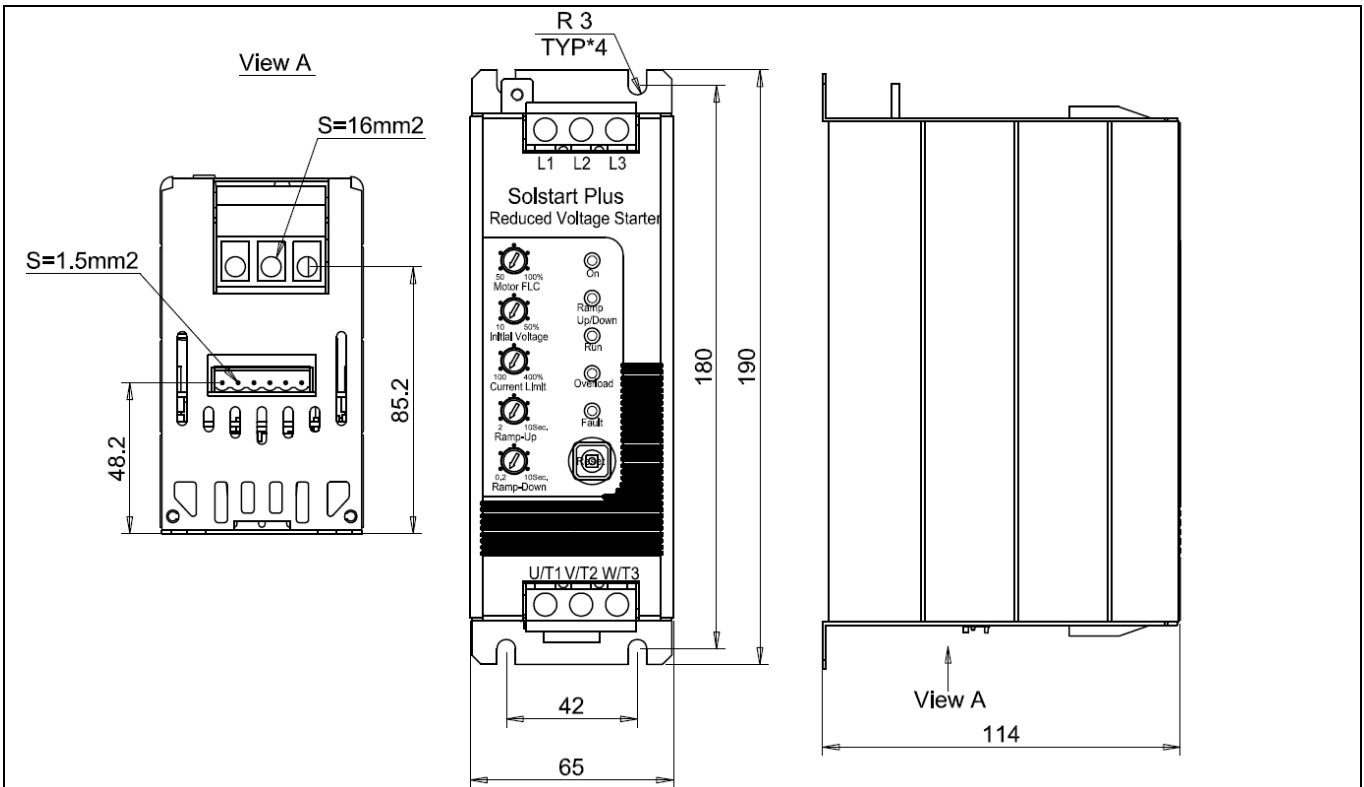

Solstart Plus 31, 44

Note: Mains voltage terminals: 16mm²

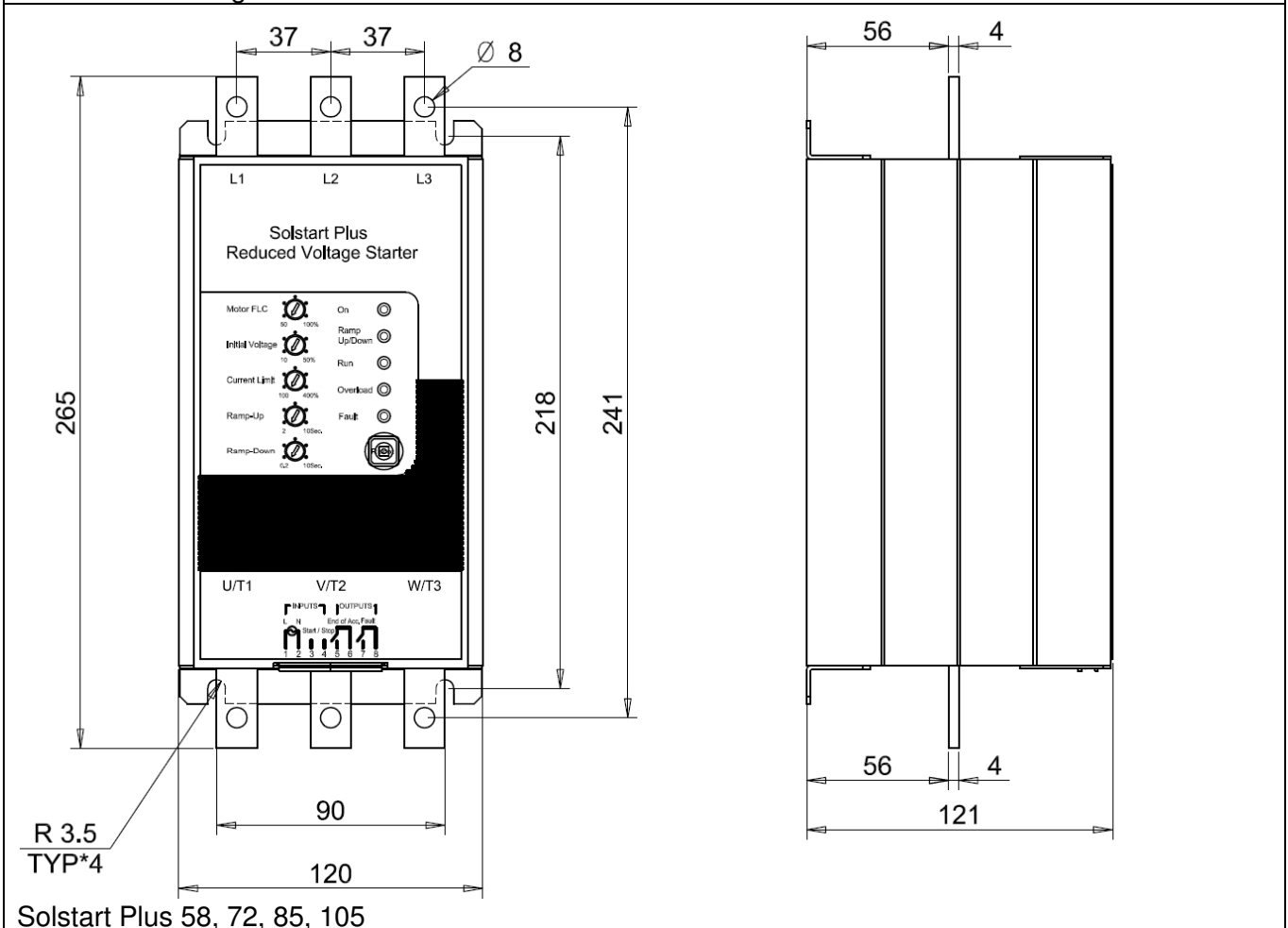

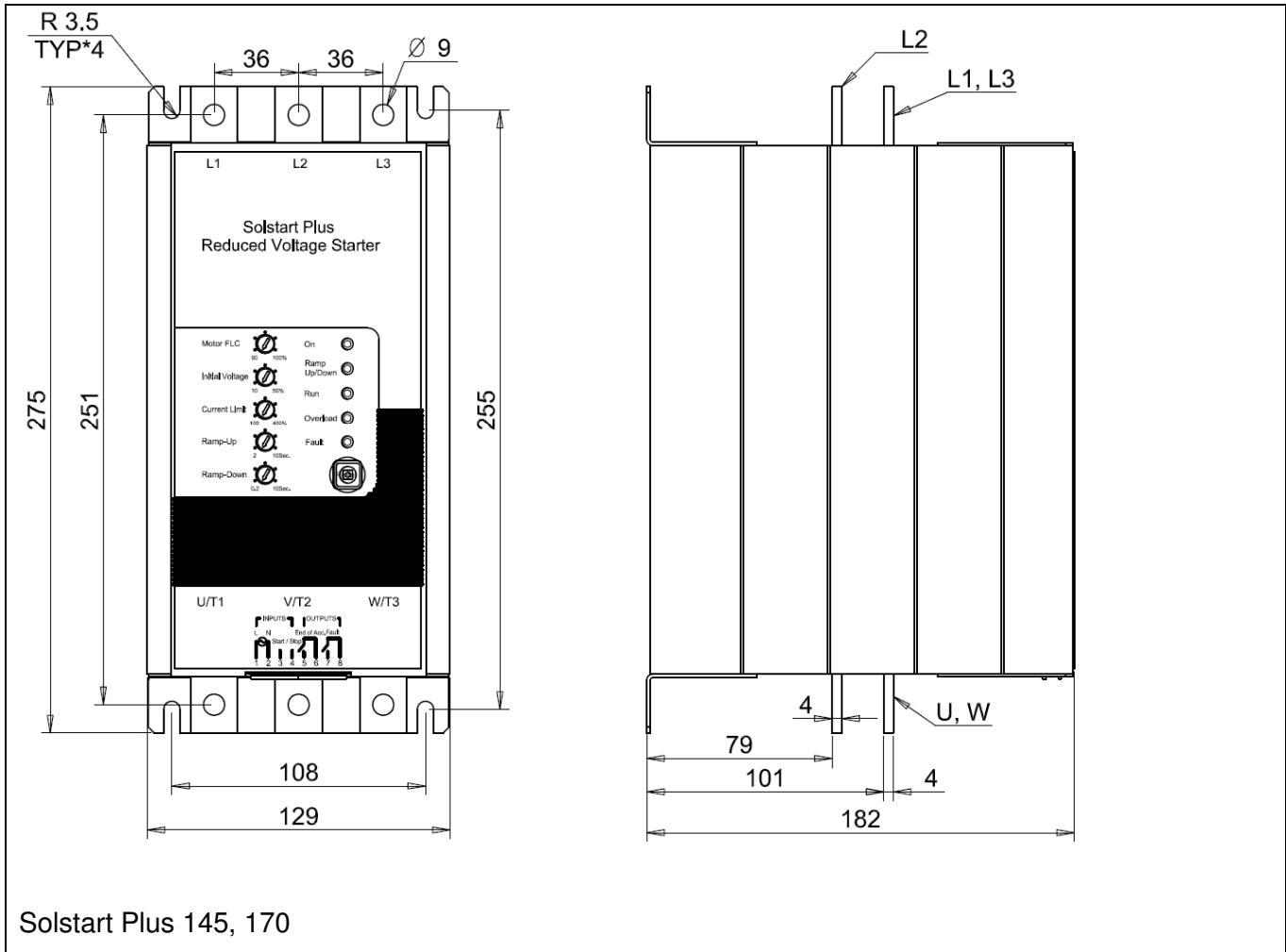

Solstart Plus 145, 170

6. INSTALLATION

WARNING!	Do not interchange line and load connections
	Do not connect the Solstart Plus "Inside Delta"

6.1 Prior to Installation

Check that Motor's Full Load Ampere (FLA) is lower than, or equal, to the starter's Full Load Current (FLC) and that Mains and Control voltages are as indicated on the starter's side label.

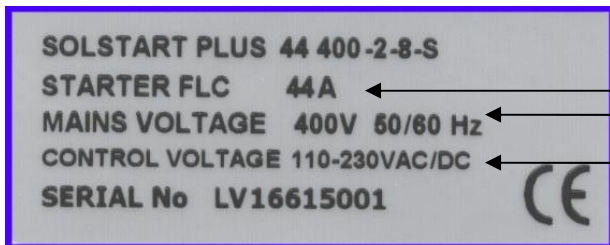

Solstart Plus label - example

- ← Make sure Starter's FLC ≥ Motor FLA!
- ← Make sure Mains voltage is right!
- ← Make sure Control voltage is right!

6.2 Mounting

The starter must be mounted vertically. Allow sufficient space (at least 100mm) above and below the starter for suitable airflow.

It is recommended to mount the starter directly on the rear metal plate for better heat dissipation.

Do not mount the starter near heat sources.

Surrounding air temperature in the cabinet should not exceed 40°C

Protect the starter from dust and corrosive atmospheres.

Note: For harsh environments (sewage treatment plants, etc.), it is recommended to order the starter with printed circuit board coating. Refer to section 3.7.1 on page 8 for ordering information.

6.3 Temperature range & heat dissipation

The starter is rated to operate over a temperature range of -10°C (14°F) to + 40°C (104°F). Relative non-condensed humidity inside the enclosure should not exceed 95%.

ATTENTION!

Operating at surrounding air temp. (Inside the cabinet) higher than 40°C may cause damage to the starter.

Starter's heat dissipation while motor is running and the internal bypass relays are closed is typically less than $0.3 \times I_n$ (in watts). During soft start and soft stop, heating is approximately two times the actual starting current (I_n watts).

Example: For a 100A motor, heat dissipation is less than 30 watts while running and during starting (for example at 350A), heat dissipation is approximately 700 watts.

Important note: If motor is frequently started, cabinet should be designed for the higher heat dissipation.

Internal enclosure heating can be reduced through the use of additional ventilation.

6.3.1 Calculating the enclosure size, for non-ventilated metallic enclosure

$$\text{Area (m}^2\text{)} = \frac{0.12 \times \text{Total heat dissipation [Watts]}}{60 - \text{External ambient temp. [}^\circ\text{C]}}$$

Where: **Area [m²]** - Surface area that can dissipate heat (front, sides, top).

Total heat dissipation [Watt] – The total heat dissipation of the starter and other control devices in the enclosure. If starter is frequently started, average power should be used.

6.3.2 Additional Ventilation

Use the following arrangement for forced ventilation of the Solstart Plus's enclosure:

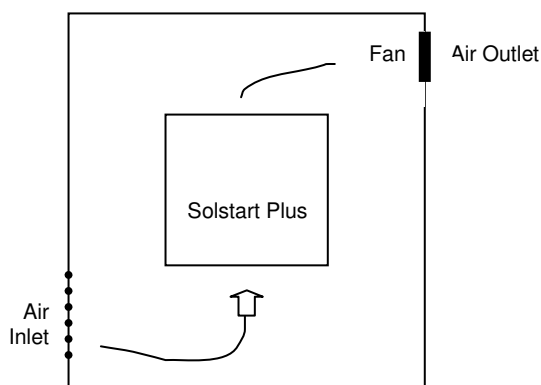

7. CONTROL KEYPAD

The control keypad is the link between the Soft Starter and the user.

The Solstart Plus control keypad features:

- (1) Five potentiometers for setting: Motor FLC, Initial Voltage, Current Limit, Ramp Up and Ramp Down.
- (2) Five indication LEDs: On, Ramp Up/Down, Run, Overload, Fault
- (3) Reset Button

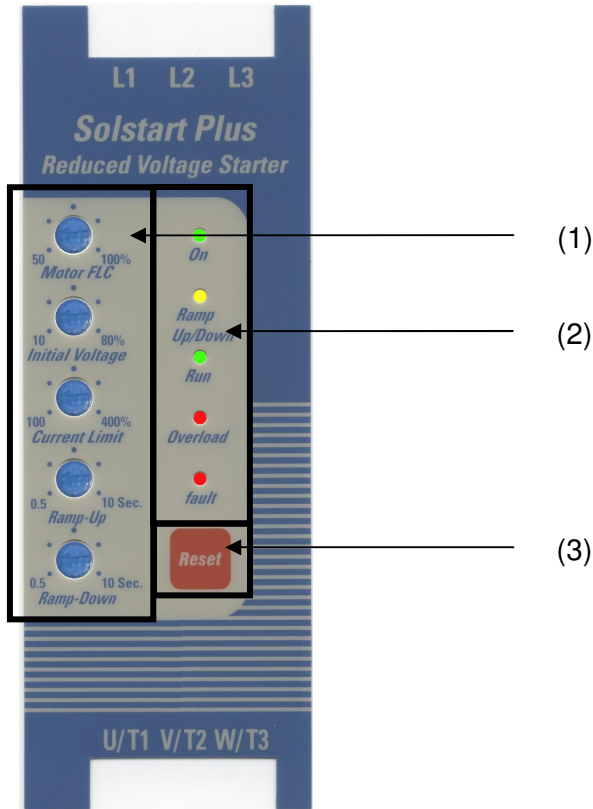





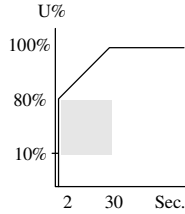
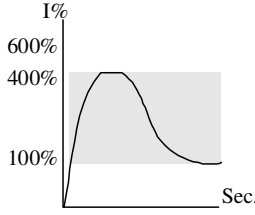
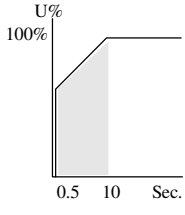

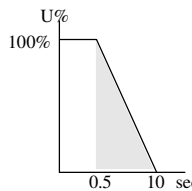
7.1 Potentiometers settings

Potentiometer	Range	Description
Motor FLC	50-100%	<p>The adjustment allows easy setting of the Solstart Plus current level, automatically adjusting current based functions (Overload, Current Limit, etc).</p> <p>Set FLC potentiometer according to the following equation:</p> $FLC = \frac{\text{Motor FLA}}{FLC} \times 100$ <p><u>Where:</u></p> <p>Motor FLA is the motor's Full Load Current rating as shown on its nameplate.</p> <p>FLC is the starter Full Load Current as shown on its label.</p> <p>Example: When starting a 27A motor using Solstart Plus 31:</p> $FLC\% = \frac{27}{31} \times 100 = 87\%$ <p>Therefore set the FLC% to a reading of 87% (see Ex.)</p>

Potentiometer	Range	Description
Initial Voltage	10-80%	<p>Determines the initial voltage to the motor (torque is directly proportional to the square of the voltage). Range: 10-80% of nominal voltage. This adjustment also determines the inrush current and mechanical shock. Too high of a setting may cause high initial mechanical shock and high inrush current (even if Current Limit is set low, as the Initial Voltage setting over-rides the Current Limit setting). Too low of a setting may result in prolonged time until motor starts revolving. The motor should start revolving immediately after Start signal</p> 
Current Limit	100-400%	<p>Determines motor's highest current during starting. Range is 100-400% of FLC (as set on motor's FLC adjustment). Too high of a setting will allow higher currents to be drawn from mains, resulting in faster acceleration. Too low of a setting may prevent the motor from completing the acceleration process and reaching full speed. Generally, this setting should be set to the highest acceptable value in order to prevent stalling.</p>  <p>Caution Starting Current and time should not exceed the allowable conditions as shown on section Error! Reference source not found. on page Error!</p>
Ramp Up	0.5-10 sec.	<p>Determines motor's voltage ramp-up time from initial to full voltage. It is recommended to set Ramp-Up Time to the minimum acceptable value (approx. 5 Sec). Notes:</p> <ol style="list-style-type: none"> Setting Current Limit low will extend Ramp-Up Time. When motor reaches full speed before voltage reaches nominal, Ramp-Up Time adjustment is overridden, causing voltage to quickly ramp up to nominal. 

Potentiometer	Range	Description
Ramp Down	0.5-10 sec.	<p>Used to control deceleration of high friction loads. When Ramp-Down potentiometer is set, upon stop signal the starter output voltage is gradually ramped down.</p> <p>When "Ramp-down Time" is set to minimum, the motor will stop immediately.</p> 

7.2 Indication LEDs and RESET button

	Green	<i>On</i>	Will lit when Control Supply voltage is connected to the starter.
	Yellow	<i>Ramp Up/Down</i>	Will lit during soft start and soft stop process, indicating that motor supply voltage is ramping up or down.
	Green	<i>Run</i>	Will lit after completion of starting process, indicating that motor is receiving full voltage.
	Red	<i>Overload</i>	Will lit upon operation of the built-in overload protection.
	Red	<i>Fault</i>	Will lit upon operation of the under voltage and phase loss protections and will flash upon operation of the heatsink over temperature protection.
		<i>Reset Button</i>	To reset the starter, after the fault has been removed.

8. **STARTING PROCEDURE**

	1	When mains voltage is connected to the Solstart Plus, even if control voltage is disconnected, full voltage may appear on the starter load terminals. Therefore, for isolation purposes, it is necessary to connect an isolating device before (upstream) the starter.
	2	Power factor correction capacitors must not be installed on starters load side. When required, install capacitors on starter's line side.
	3	Before starting the motor verify its rotation direction. If needed, disconnect the rotor from the mechanical load and verify the right rotation direction.
	4	Prior to Start up procedure make sure that line voltage and control voltage match the ones shown on the starter's name plate.
	5	Do not interchange line and load connections
	6	Do not connect the Solstart Plus "Inside delta".

8.1 Standard starting procedure

1. Set FLC (Motor Full Load Current) - according to calculation:

$$FLC = \frac{\text{Motor FLA}}{\text{Starter FLC}} \times 100$$
2. Set other potentiometers according to system requirements (see next page for examples)
3. Connect Control Supply. On LED will lit.
4. Connect mains voltage to starter line terminals.
5. Apply Start command

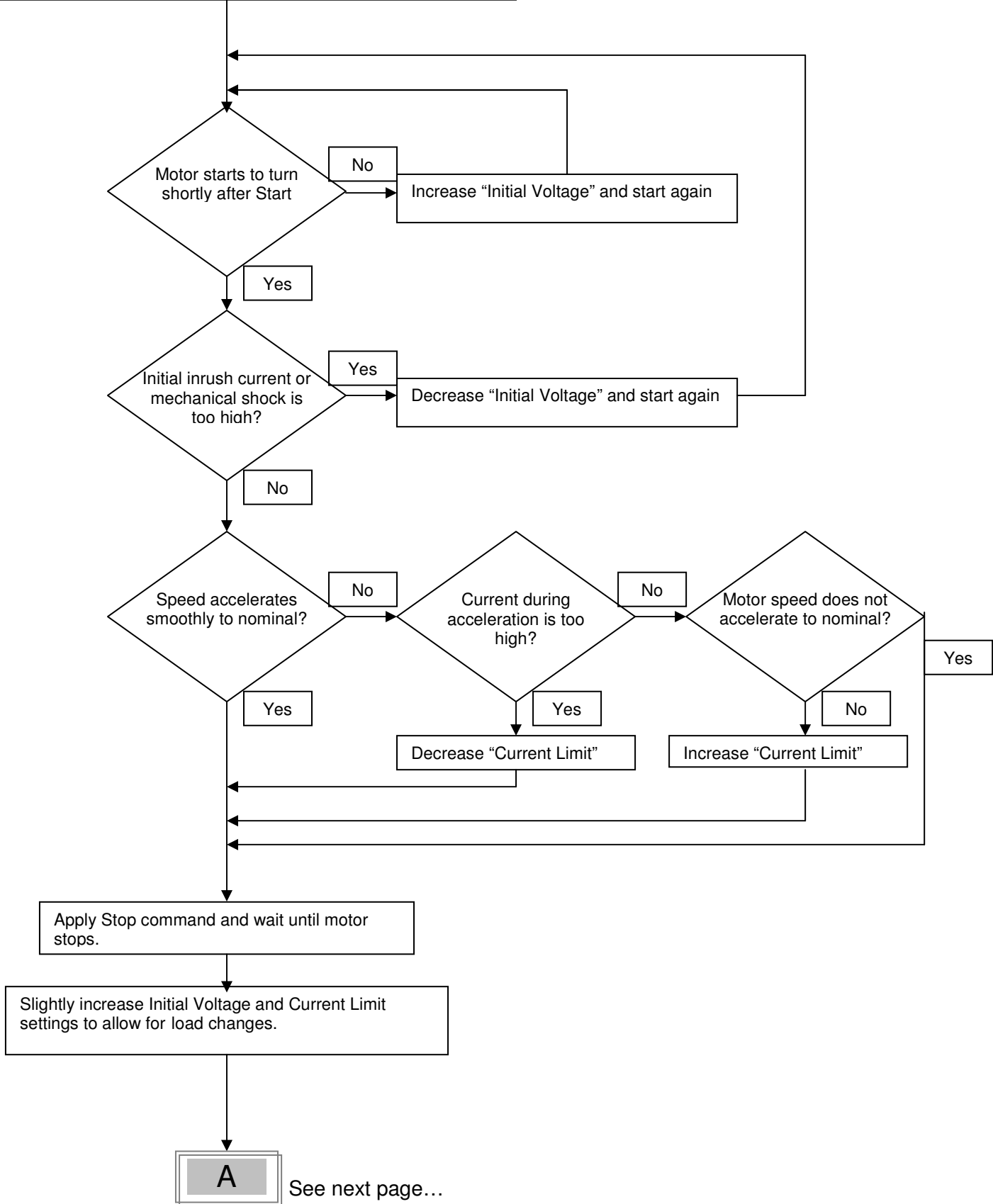

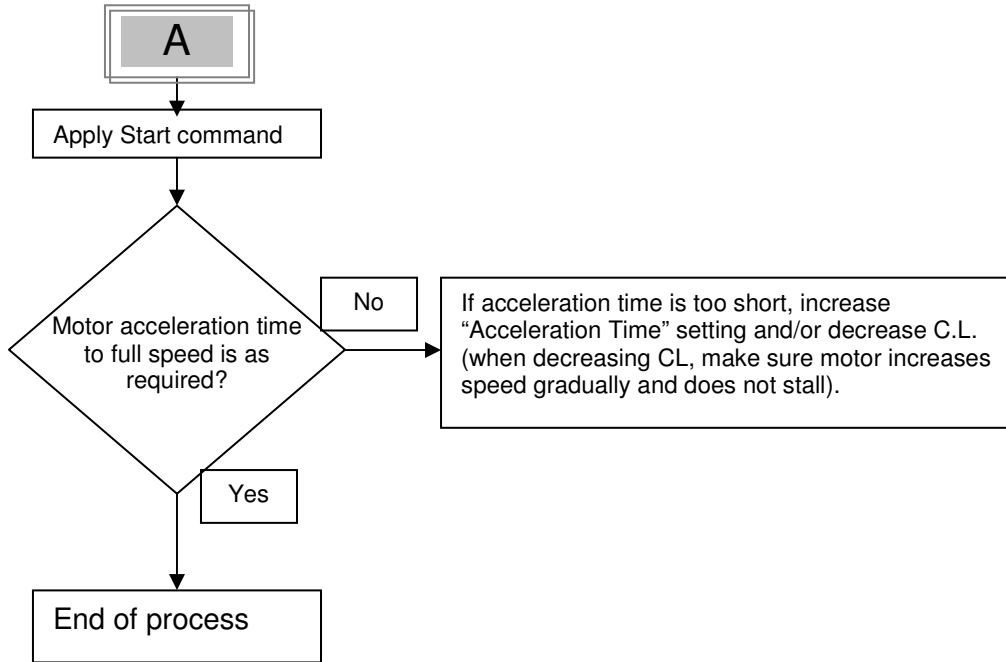

8.2 Examples of starting curves

Light loads - pumps, etc.

Current limit - set to 300%

Initial Voltage - set to 30%

Ramp-up time - set to 5 sec.

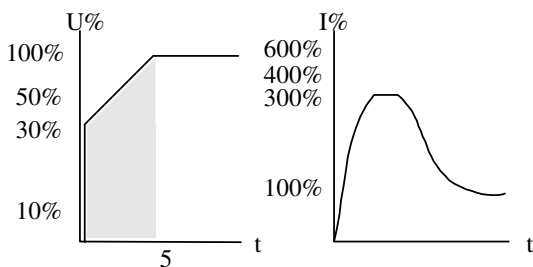

Upon start, the voltage quickly increases to the Initial Voltage value (30% U_n) and then gradually ramps-up to nominal.

The current will simultaneously increase to peak current value, which can be the Current Limit setting or less, before smoothly decreasing to the operating current. The motor will accelerate to full speed quickly and smoothly.

High inertia loads – crushers, centrifuges, mixers etc.

Current Limit - set to 350%

Initial Voltage - set to 50%

Ramp-Up time - set to 5 sec.

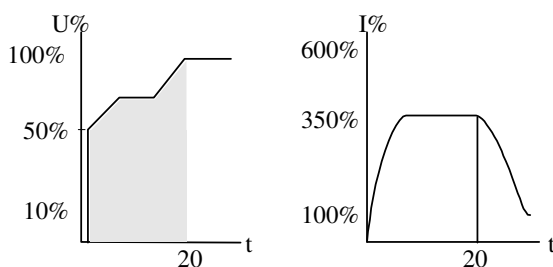

Upon Start the voltage and current increase until current reaches Current Limit value. The voltage remains at this value until motor reaches nominal speed, where current starts to decrease, voltage continues to ramp-up to nominal. At this time, the motor should have smoothly accelerated to full speed.

9. TROUBLE SHOOTING

Upon fault – motor stops, *Fault* LED lights and Fault Relay operates.

Fault Message	Cause and trouble shooting
Overload LED lights.	Trips the starter when current exceed the overload level and thermal register has filled up. <i>Check FLA, FLC and Overload settings, check motor current, wait 15 minutes to let motor and starter cool down before restarting.</i>
Fault LED lights	Trips when under voltage protection or phase loss protection has activated. <i>Check that all 3 phases are within voltage limits.</i>
Fault LED flashes	Heat-sink over-temperature. Trips the starter when heat-sink temp. rises above 85°C. <i>Check that motor starting is not too frequent, check ventilation and surrounding air temperature.</i>

9.1 Warranty Claim and Fault Inquiry

Representative Name:	Country:	Fax Number:
Model Number And Build Options:	Example: 170 – 400 – 2 – 8 – S Solstart Plus _ _ _ - _ _ _ - _ - _ + _ _ - _	
Serial Number:		
Purchasing Date:		
Sale / Installation Date:		
Failure Date:		
Draw one line diagram:		
Draw control diagram:		
Define time of fault occurrence: (during start, after start, during soft stop, end of soft stop, when closing ByPass.....)	23	
Starter Operative Information		
Starter FLC:		
Motor FLC:		
Initial Voltage:		
Acceleration Time:		
Current Limit:		

10. TECHNICAL SPECIFICATIONS

<u>Environment</u>		
Mains voltage	Three phase, line to line, 208V-176-242 Vac 50 / 60 Hz 400V-340-440 Vac 50 / 60 Hz 480V-408-528 Vac 50 / 60 Hz 600V-510-660 Vac 50 / 60 Hz	
Control Voltage	110 – 230 VAC(50/60Hz)/DC	Incorporates a universal power supply unit for DC and AC
Load	Three-Phase, Three-Wire, Squirrel Cage Induction Motor	
Degree of protection	IP 20 for models 31 and 44 IP00 for all other models.	
Altitude	1000 m above sea level	Consult factory for derating
<u>Adjustments</u>		
FLC (Full Load Current)	50% - 100%	
Starting Torque (Initial Voltage)	10-80 % of full voltage	
Current limit	100 % - 400% of nominal current	
Ramp Up Time (soft start)	0.5 - 10 sec.	
Ramp Down Time (Soft Stop)	0.5 - 10 sec.	
<u>Protection</u>		
Electronic Overload	Inverse time (I^2t), factory preset at 115% of FLC, active only during Run.	
Phase Loss	Trips when one phase is missing	
Under voltage	Trips when voltage is not within allowed limits.	
Heatsink Over temperature	Trips when the heatsink temperature exceeds 85°C.	
Reset buttons	To reset the starter, after the fault has been removed.	
<u>Indications</u>		
Indication lights (LEDs)	ON - Green	Lights when control voltage is connected to the Solstart Plus.
	Ramp Up / Ramp Down – Yellow	Lights upon start signal or during soft stopping.
	RUN – Green	Lights upon end of starting. When the internal bypass relays close.
	Overload – Red	Light when overload condition is detected.
	Fault – Red	Flashes when the heatsink temperature rises above 85°C. Lights when phase loss and under voltage protections have activated.
<u>Temperatures</u>		
Operating	-10° to 40°C	
Storage	-20° to 70°C	
Relative humidity	93 % - non condensed	
<u>EMC</u>		
Immunity to radio electric interference	EN 1000-4-3 level 3	Conforming to EN 60947-4-2
Electrostatic discharge	EN 1000-4-2 level 3	Conforming to EN 60947-4-2
Immunity to electrical transients	EN 1000-4-4 level 4	Conforming to EN 60947-4-2
Shock waves of voltage / current	EN 1000-4-5 level 3	Conforming to EN 60947-4-2
Radiated and conducted emissions	EN 1000-4-6 level 3	
Radio frequency emissions	According to EN 55011 class A	Conforming to EN 60947-4-2

<i>Output relays</i>	
End of Acceleration Contact	Exists in models Solstart Plus 58A and up. N.O., 8A / 250VAC, 1800VA max..
Fault contact	N.O , 5A, 250VAC, 1250VA max. Solstart Plus up to 44A. N.O , 8A, 250VAC, 1800VA max. Solstart Plus 58A and up.

SOFTSTART UK
www.softstartuk.com

Softstart UK Ltd.
PO Box 215
Great Yarmouth
Norfolk
NR31 0LU

Tel: +44 (0) 1493 660510
Fax: +44 (0) 1493 660511